

LKF1270

SEATED TRICEPS EXTENSION TECHNICAL SPECIFICATIONS

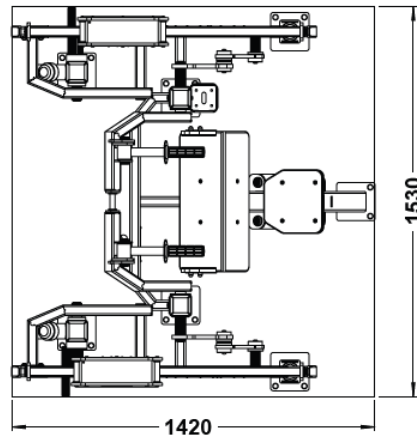

Safe Settlement Area Measure

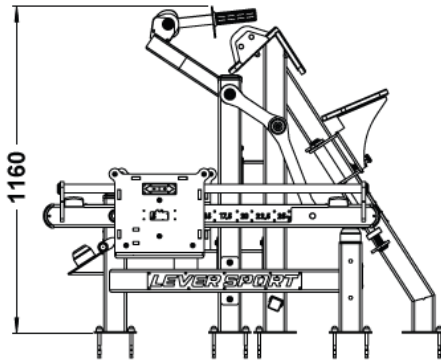
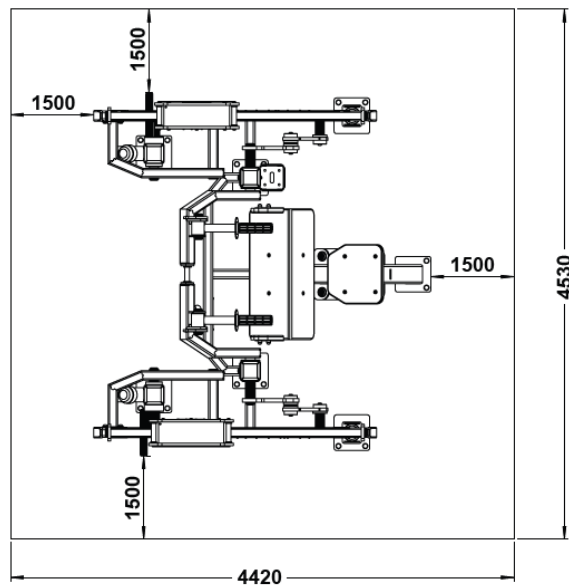

1. SCOPE

This specification covers the technical characteristics of the mechanical Seated Triceps Extension machine, designed for use in outdoor sports areas, which targets the upper body muscles.

2. GENERAL FEATURES

All metal parts shall be sandblasted.

The machines will feature a compartment for users to store their phones and drinks.

Each machine will feature a QR code providing access to a video explaining the correct use and operating principle of the product.

Each part will be packaged to prevent friction and scratches during transport.

Products will not have any sharp edges or surface details that could cause harm to the human body during use. Contact points will consist of rounded lines and curves.

3. SURFACE TREATMENTS AND PAINT

Oil, rust, and dirt on metal surfaces will be cleaned using a pressurised air spraying method.

The material surface will be sandblasted to open pores, ensuring better adhesion of the zinc primer and paint.

After sandblasting, all metal surfaces will be painted with zinc primer-coated electrostatic paint.

4. MECHANICAL SYSTEM AND BODY STRUCTURE

Square profiles measuring 80 x 80 x 4 mm will be used in the main body of the machine.

Rectangular profiles measuring 40 x 80 x 4 mm will be used in the moving load arms.

The shaft connecting the main body and the load arms will have a diameter of Ø40 mm.

The moving load arms will be connected to the main body with self-sealed bearings.

6206 surface-coated bearings will be used.

The bearing systems will be protected against water, dust and external factors with polyamide-based covers produced by plastic injection moulding.

The machine will be manufactured for use by multiple persons.

5. WEIGHT SYSTEM

The weight increment system will be designed to increase by 5 kg at each level.

The minimum working weight will be 5 kg, and the maximum working weight will be no less than 25 kg.

The product will be manufactured as a dual weight unit; the total weight will be 50 kg.

The weight system is designed to allow users to operate both sides independently.

The weight system will have a mechanism that can slide equally on the right and left load arms.

The mechanism will be capable of operating on both sides and will provide dual-sided usage.

The user can lock the weight lifting arms using the sliding system and operate both arms together or one arm independently of the other. The locking mechanism will be made of stainless chrome-plated material.

One wheel will be used in each weight system, and each wheel system will have two sealed and surface-coated bearings.

The weight system will move forward and backward on a 40x80x4 mm load arm with Ø 90 mm wheels.

UV-printed aluminium labels will be used as kilogram increase/decrease indicators. (Absolutely no foil or adhesive labels will be used.)

The profile rails on which the weight moves will be covered with wear and corrosion-resistant stainless steel sheet.

The weight system will be equipped with a double-sided locking mechanism that prevents forward and backward movement during operation.

The locking mechanism will operate via a Ø21x2 mm steel tube, and Ø30 mm rubber hand grips (93 mm) will be located at the user contact points.

A Ø20 mm chrome shaft will be used to ensure the integrity of the weight system.

The weight system will move horizontally on a Ø30 mm chrome shaft and slide on CrNi 304 stainless steel sheet with the aid of wheels.

6. SAFETY AND ERGONOMICS

Ø72x52 mm rubber buffers will be used to prevent impact.

To prevent metal-to-metal contact, 45x68x35 mm elliptical rubber buffers will be mounted on 40x80 profiles.

For user safety, half-circle, square, or elliptical polyamide caps will be fitted to the ends of the 40x80 – 80x80 profiles.

7. SEAT AND ADJUSTMENT MECHANISM

The seat platform will be vertically adjustable according to the user's height.

The adjustment mechanism will operate on sliding bearings and Ø20 mm stainless steel pins.

Locking holes and a stainless steel safety pin will be provided for height adjustment.

Metal parts with pins will be manufactured from 2 mm CrNi 304 stainless steel sheet.

8. SUPPORTS AND HANDLES

The back, chest and seat platforms will be manufactured from vandal-resistant 19 mm thick UHDPE (Ultra High Density Polyethylene) material.

The handrails will be manufactured from Ø34 and 48*3 mm tubing. To prevent hands from slipping on the handrails, a PVC-added product containing synthetic rubber, which is unaffected by adverse weather conditions and sunlight, will be used.

10. DIMENSIONS AND ASSEMBLY

The passive (closed) dimensions of the machine shall be at least 1530 mm width x 1420 mm length x 1160 mm height.

The product shall be fully disassemblable for transport.

The products shall be manufactured in accordance with EN16630 standards.